

A0 INSTALLATION DRAWING

IF THIS DOCUMENT IS PRINTED IN HARD COPY, IT IS FOR INFORMATION USE ONLY AND THEREFORE IS NOT SUBJECT TO UPDATING CONTROLS. ALWAYS REFER TO SOLIDWORKS VIEWER FOR LATEST ISSUE



THIS DRAWING IS CONFIDENTIAL AND IS SUPPLIED ON THE EXPRESS CONDITION THAT IT SHALL NOT BE LOANED OR COPIED OR DISCLOSED TO ANY OTHER PERSON OR USED FOR ANY OTHER PURPOSE WITHOUT THE WRITTEN CONSENT OF AP RACING LTD.

AP Racing
Wheler Road
Coventry
CV3 4LB
Tel: +44 (0)24 7663 9595
Fax: +44 (0)24 7663 9559
e-mail: sales@aprac.com
Web site: HTTP://www.aprac.com

CALIPER SPECIFICATION	
PISTON AREA	25.05cm ² (PER PAD) 50.1cm ² (TOTAL)
DISC DIAMETER MAX	410.00 (SWEEP DEPTH = 67.07")
DISC DIAMETER MIN	370.00 (SWEEP DEPTH = 65.00")
DISC THICKNESS MAX	36.00
DISC THICKNESS MIN (WORN CONDITION)	35.00 (DIFFERENTIAL WEAR NOT TO EXCEED 0.50mm SIDE TO SIDE)
DISC ROTATION	ROTATING DISC MUST PASS SMALLEST PISTON FIRST **
WORKING PRESSURES	SEE DATA SHEET P14.378 (AVAILABLE FROM AP RACING TECHNICAL DEPARTMENT)
DRY WEIGHT (LESS PADS)	4.60kg (EST)
DRY WEIGHT (INC. PADS)	6.59kg (EST)
PAD RETENTION	2 x FRICTION RETAINED PINS
RECOMMENDED WHEEL/CALIPER CLEARANCE	4.00 (MIN)
RECOMMENDED PAD FRICTION MATERIAL	APF405
SEAL KIT	CP4527-CEJ
ANTI-RATTLE CLIP	CP9555-110
PAD RETAINING PIN	CP7555-116
EVLV COMPLIANCE	ALL MATERIALS AND COATINGS COMPLY WITH END OF LIFE VEHICLES (2000/53/EC)

AVAILABLE PART NUMBERS	
PART NUMBER	DESCRIPTION
CP9572-250##	RIGHT HAND TRAILING (BEHIND AXLE)
CP9572-350##	LEFT HAND TRAILING (BEHIND AXLE)
CP9572-450##	RIGHT HAND LEADING (IN FRONT OF AXLE)
CP9572-550##	LEFT HAND LEADING (IN FRONT OF AXLE)
## = COLOUR CODE	
FOR AVAILABLE COLOURS AND FURTHER TECHNICAL INFORMATION PLEASE REFER TO THE PRODUCT CATALOGUE, APRACING.COM OR CUSTOMER SERVICES	

CALIPER INSTALLED POSITION	VEHICLE CONFIGURATION	
	FRONT ENGINE	REAR ENGINE
FRONT AXLE APPLICATION	3500 kg (7720 lbs)	4100 kg (9040 lbs)
REAR AXLE APPLICATION	6140 kg (13540 lbs)	4900 kg (10800 lbs)

MAXIMUM WORKING CALIPER PRESSURE 250 Bar (3650 Psi)

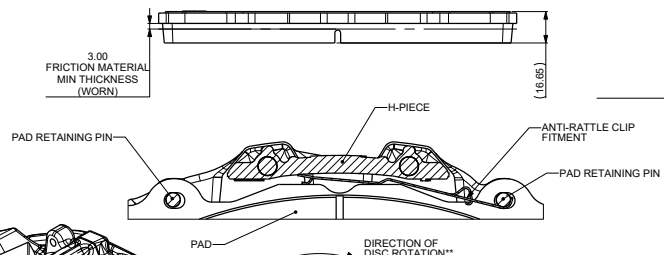
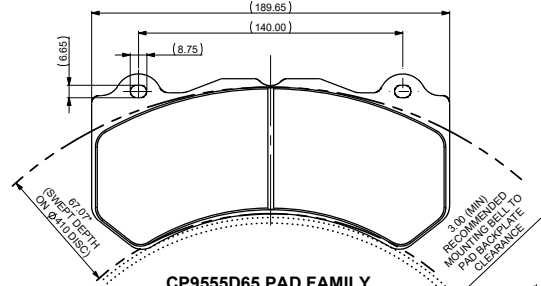
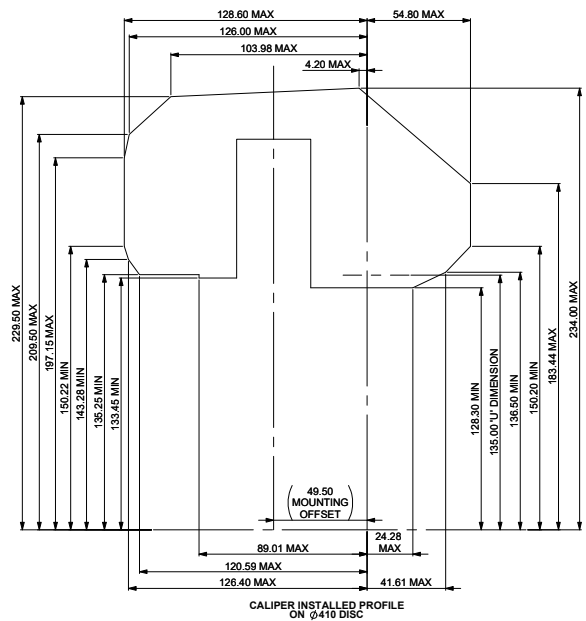
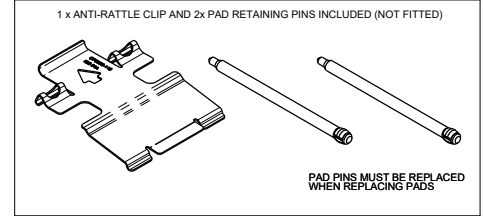

CAUTION - THE EXTERNAL PIPE IS A NON-SERVICEABLE ITEM AND MUST NOT BE TAMPERED WITH UNDER ANY CIRCUMSTANCES.

FEED PORT M10 x 1.0
9.50 MIN FULL THREAD

TYPICAL TIGHTENING TORQUE:

- FITTING WITH ONE COPPER GASKET - 13NM +45°
- FITTING WITH TWO COPPER GASKETS - 13NM +90°

RESULTING MAX TORQUE MUST NOT EXCEED 30NM.

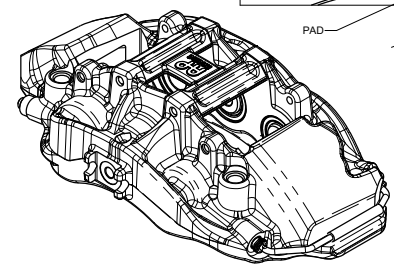
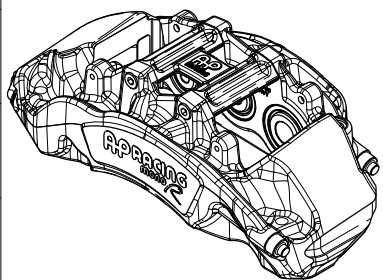
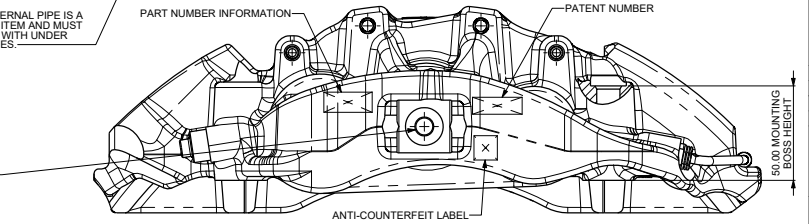
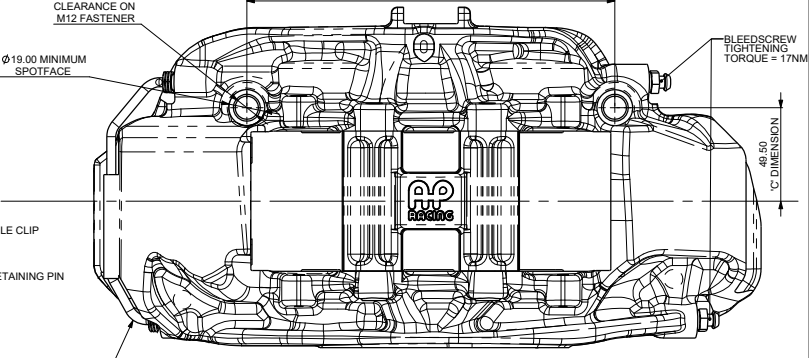
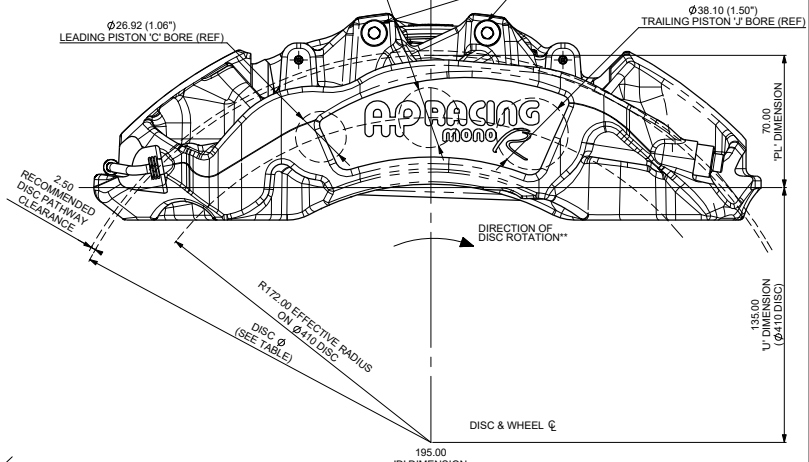
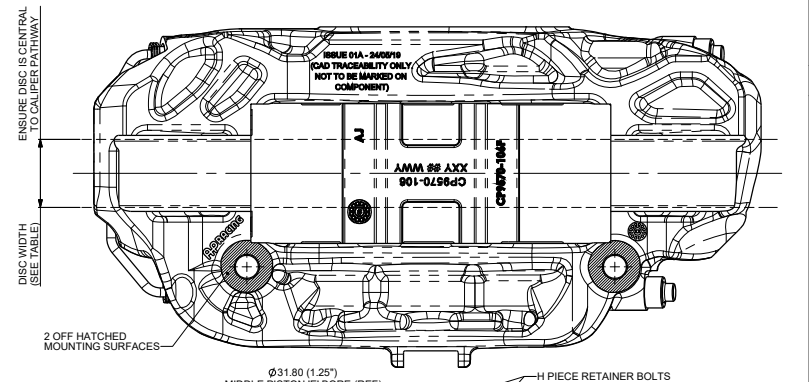

Rev	Date & No.	Particulars	By	Chk
01	06/06/2019	FIRST ISSUE		
	R4501_05			
02	31/10/2019	COMPATIBLE DISC TABLE REMOVED		
	R4501_15	CALIPER MAX GVW TABLE ADDED		
		CALIPER MAX GVW TABLE ADDED		
		LASER ETCHING DETAILS & ANTI-COUNTERFEIT LABEL LOCATION ADDED		
03	08/11/2019	CALIPER MAX GVW TABLE UPDATED		
	R4501_16			
		CALIPER MAX WORKING PRESSURE UPDATED WAS 130 BAR NOW 250 BAR		
04	10/08/2022	'AVAILABLE COLOURS' REMOVED FROM SPEC TABLE		
	R5010_02			

SCALE 1:1	SHEET 1 OF 1
DRAWN JHALEY	
APPROVED	
DERIVED FROM CP9555-1CD	
TITLE	
6 PISTON HPK MONOBLOC CALIPER	
Ø26.92xØ31.80xØ38.10 PISTON SIZES	
DRG NO.	CP9572-1CD